

CHAÎNE DE RAGUAGE C CHAFE CHAIN C

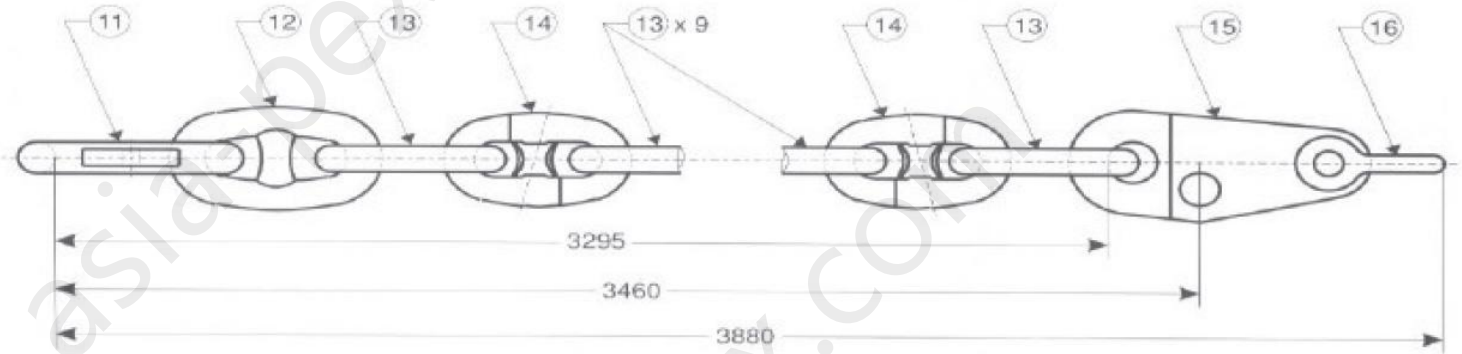

Maille d'extrémité End Link	Rep	A mm	B mm	C mm	D mm	E mm
	11	255	100	68	123	42

Maille Ordinaire - Grande maille Common link - Enlarged link	Rep	A mm	B mm	C mm
	12	232	209	58
	13	216	194	54

Kenter Kenter joining shackle	Rep	A mm	B mm	C mm
	14	216	226	54

Plaque triangulaire d'extrémité Small tri-plate	Rep	F mm	G mm	H mm	I mm
	15	58	350	72	70

Manille d'extrémité End shackle	Rep	J mm	K mm
	16	139	51

Matière : Chaîne Grade 3 ou ORQ.
Plaque triangulaire en acier moulé haute résistance.
Manille en acier forgé.
(Voir 905-2).

Material : Chain in Grade 3 or ORQ quality.
Small tri-plate in cast steel.
Shackle in forged steel.
(See 905-2).

CODE	TYPE	Qualité Quality	Charge de travail SWL kN	Tension Proof load kN	Rupture Breaking load kN	 kg
Chafchai C	C	U3	981	1 590	2 265	295

For Information Purposes Only